

# INSTALLATION INSTRUCTION

SECTION INSULATOR FO / FS / FD

V0914

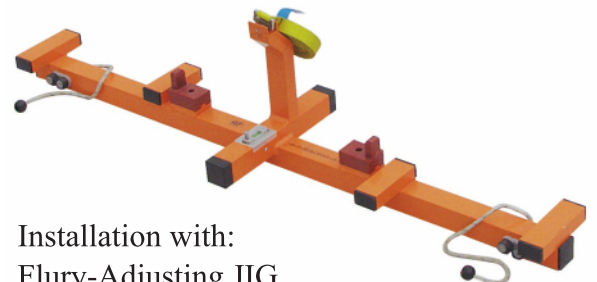

Installation with:  
Flury-Adjusting JIG  
Article number 655.300.000

## Accessories for installation of the FLURY section insulator

- 1 Spring balance (Article number 655.181.000)
- 1 Ring spanner 17 mm
- 1 Torque wrench 17 mm [50 Nm (37 ft lbf)]
- 1 Flury-Adjusting JIG
- 1 Level gauge (Article number 655.141.000)
- 1 Metal cutter (+ maybe 1 metal saw)
- 1 Ratchet with hexagon pin insert 5mm

- 1 Hammer
- 1 Flat nose pliers or gas pliers
- 1 Straightening wood
- Additionally for:
  - *Cut-in the messenger wire insulator*
  - *Replacement of a used section insulator*
- 1 Pulley block with 2 cable sockets

## Preparation of contact and messenger wire

Straighten the contact wire at the installation location and make sure it is not twisted!

Each section insulator should be well centred and aligned parallel to the track.

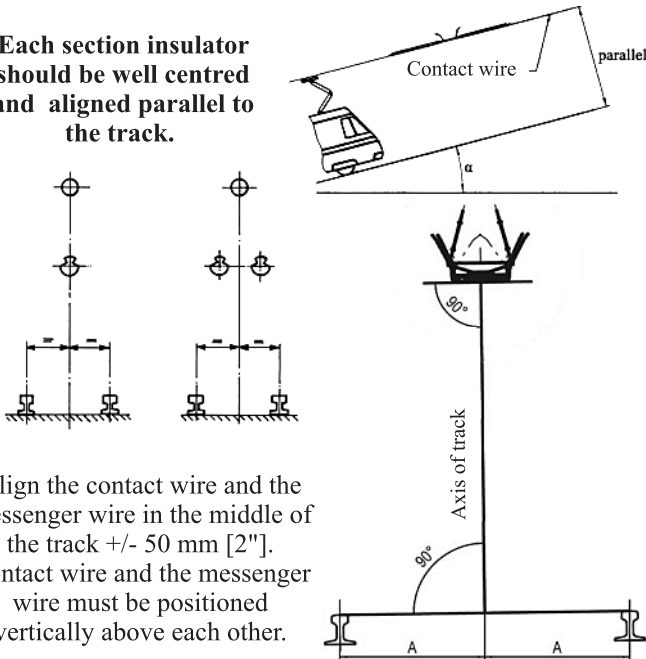

Align the contact wire and the messenger wire in the middle of the track +/- 50 mm [2"]. Contact wire and the messenger wire must be positioned vertically above each other.

## Hogging Instruction

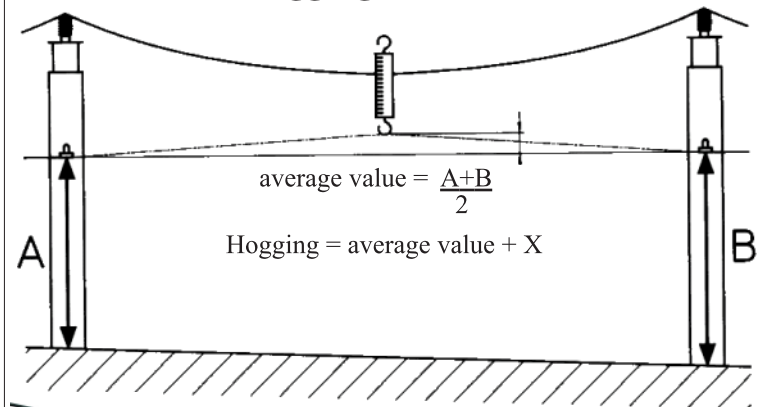

Measure the height of the contact wire at the guide arm clamps before (A) and after (B) the installation location. Calculate the average value. Use a spring balance and pull the contact wire with 120-150 N [26-33 lbf] to measure the possible excess height (value x)



## Installation Location

- a) In autotensioned systems, install the section insulator mid span.
- b) If the messenger wire is fix terminated install the section insulator near to a cantilever. Mounting angle max. 5°.

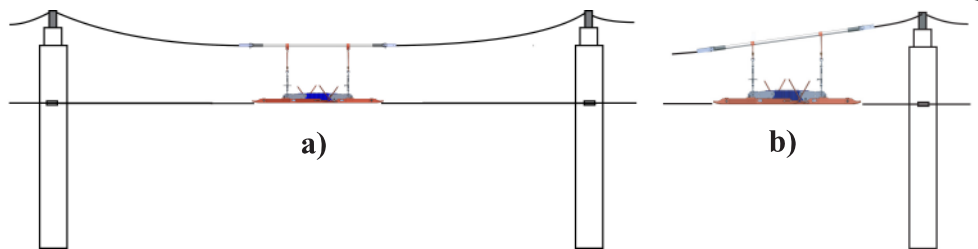

**! RISK OF DEATH !**

Do not begin to work on the overhead line before you have ensured that it is switched off and correctly grounded!

# 1. Alignment of the JIG

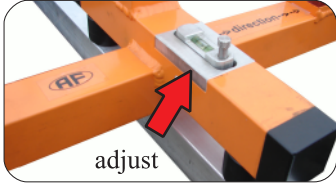
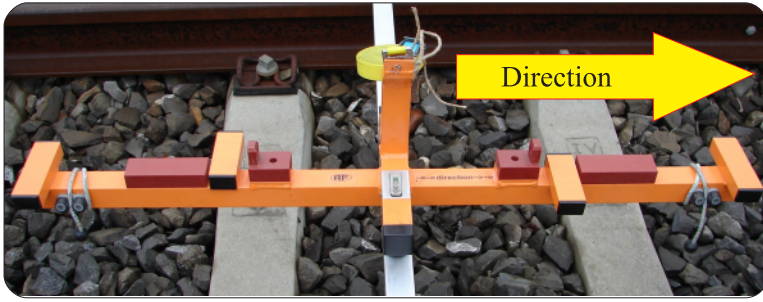

Place the JIG in a user-defined installation direction. Adjust the level gauge.

# 2. Install messenger wire insulator



First install the messenger wire insulator with saddle clamp and cable hangers.

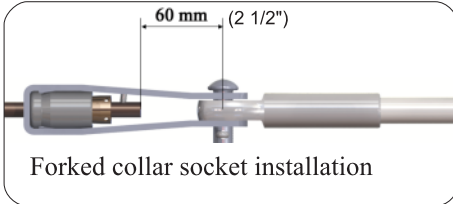

# 3. Preparation for installation

Take off the runners, the counter nuts and the safety wires of the turnbuckles. Loosen contact wire clamps and open turnbuckles completely.

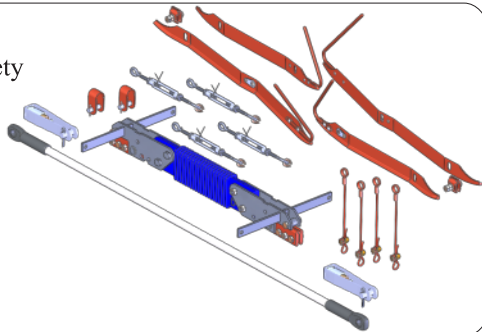

# 4. Mount section insulator onto contact wire without runners.

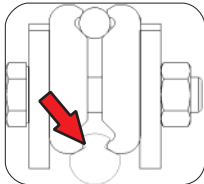

**Warning!**  
The teeth of the contact wire clamps must grip over the full length into the groove.

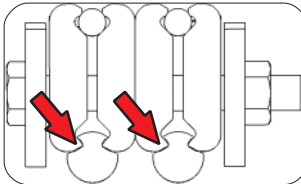

Tighten the bolts of the contact wire clamp with 50 Nm (37 ft lbf) by using a torque wrench and retighten 3 times.

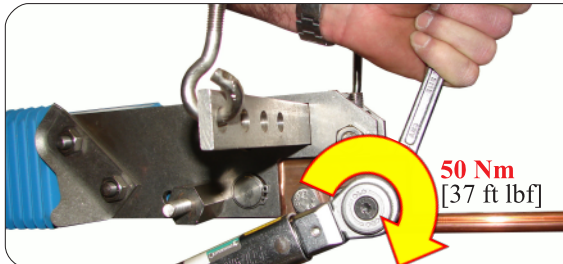

Mount counternuts and block [50 Nm (37 ft lbf)]

50 Nm [37 ft lbf]

# 5. Cut contact wire

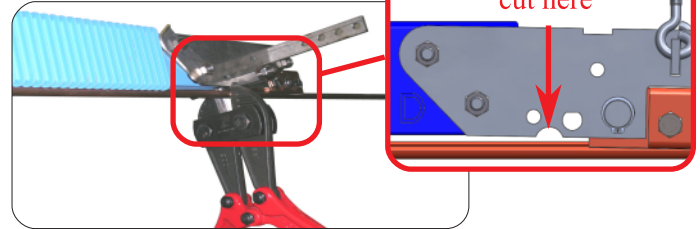

# 6. Bend contact wire ends up

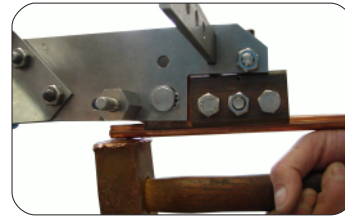

# 7. Repair buckling

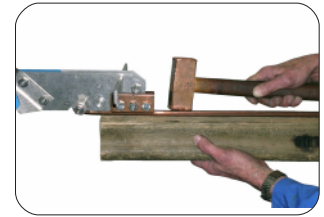

# 8. Installation of the JIG, fix the rope

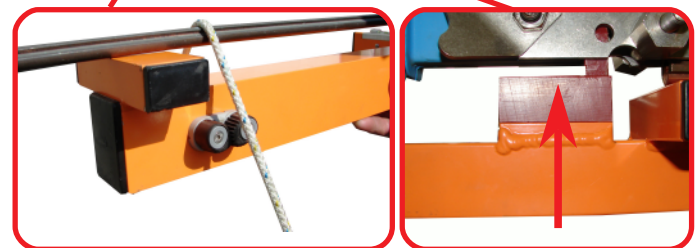
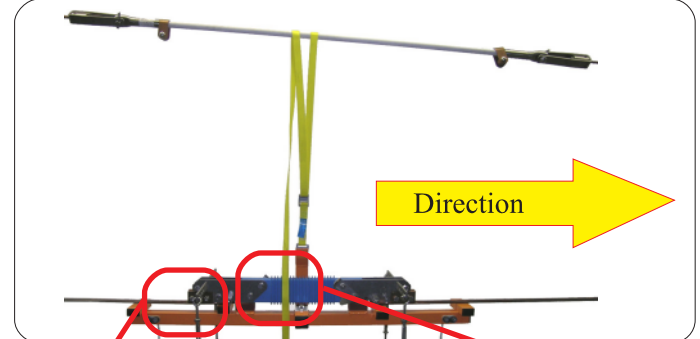

# 9. Hogging

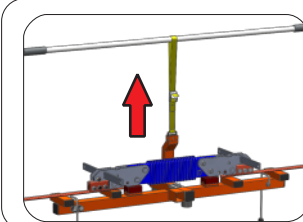

Use the rope on the JIG for the adjustment of the hogging. Adjust the section insulator height according to Hogging Instruction on page 1 [if not known value = 70mm (2 3/4")].

# 10a. Adjust the prestress Only for section insulator with adjustment mechanism

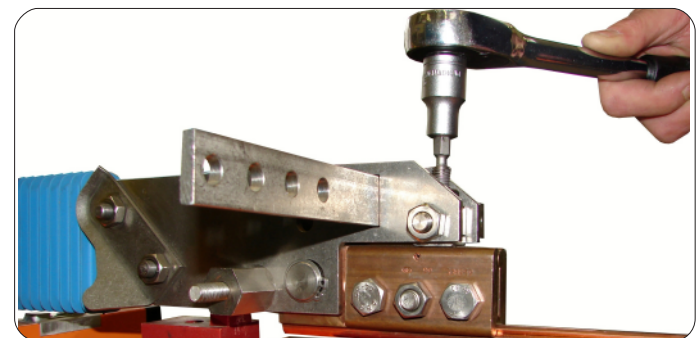

## 10b. Control the prestress

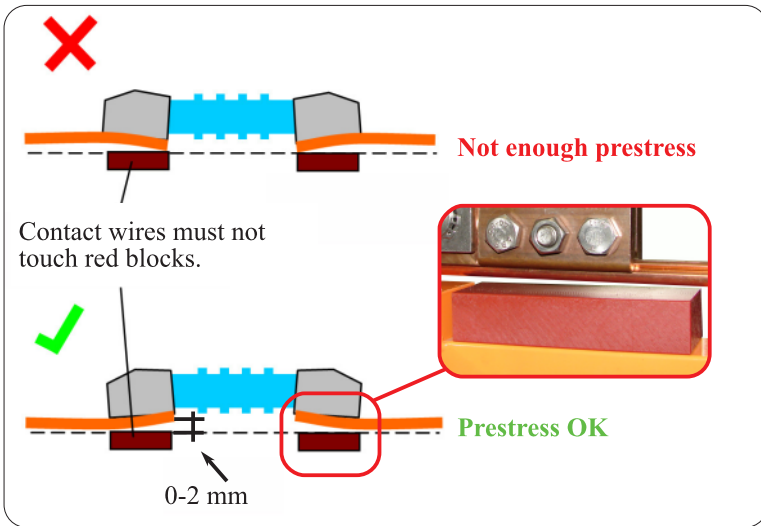

## 10c. Lock the adjusting screws with the counter nuts 25 Nm [18.5 ft lbf]

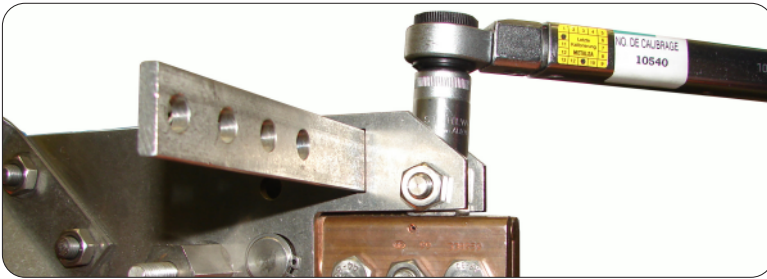

## 11. Mount and adjust the suspension

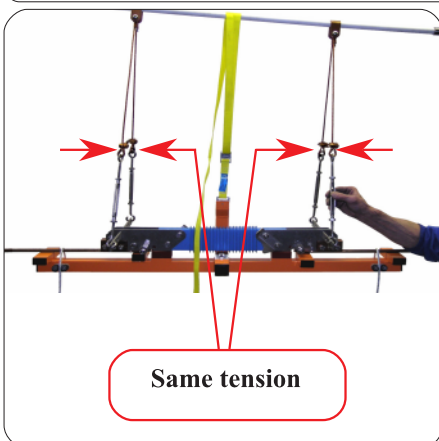
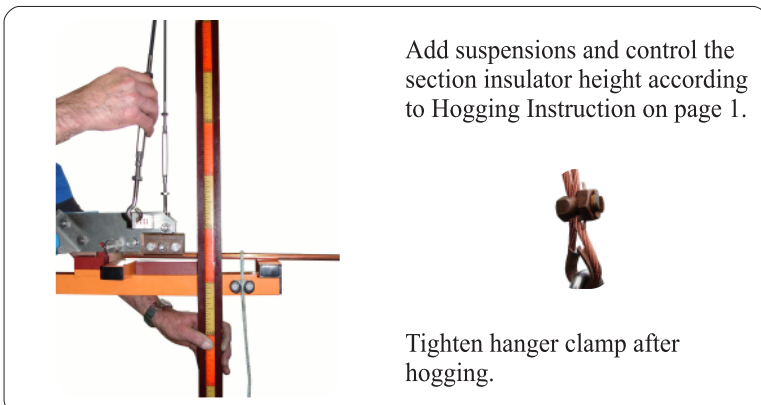

## 12. Mount the runners

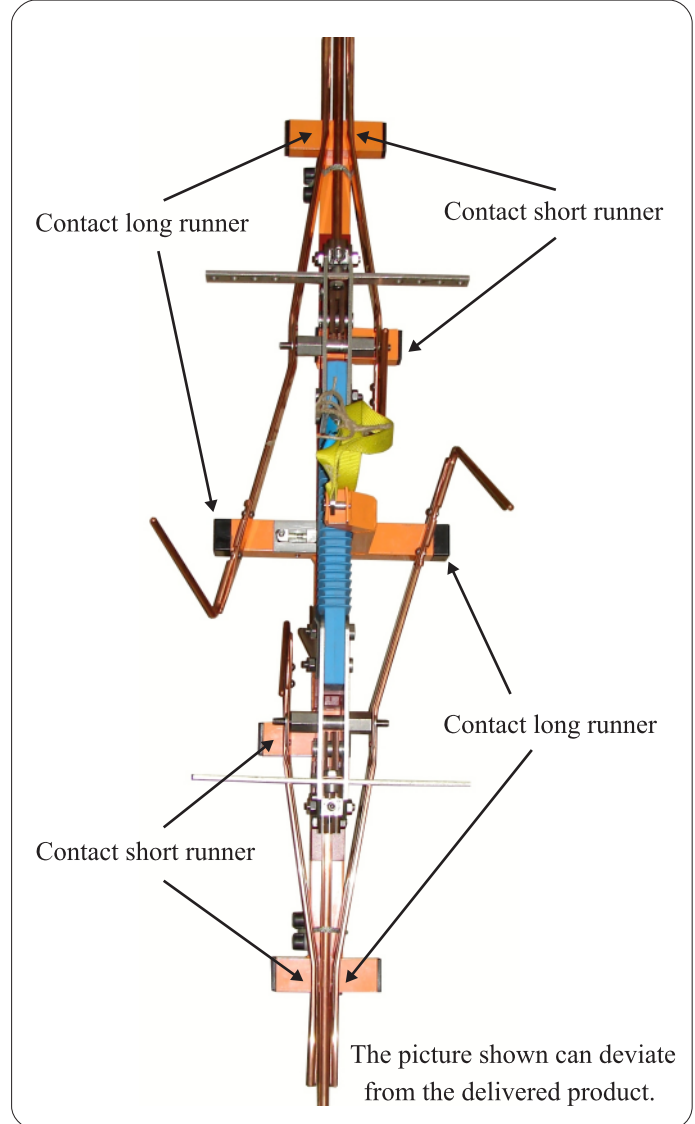

## 13. Tighten the runner fixation



## 14. Tighten the nuts with 50 Nm [37 ft lbf] and counter with the second

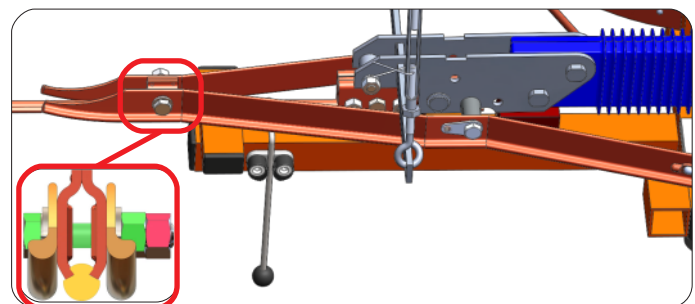

## 15. Check gliding

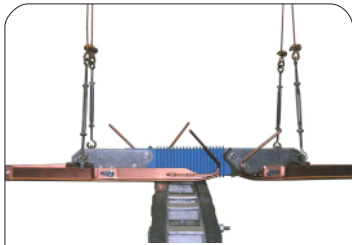

Check with spirit level or pantograph for optimal gliding.

## 16. Block turnbuckles



Check all counter nuts once more. Block turnbuckles with counter nuts.

## 17. Secure turnbuckles



Lock turnbuckles with a locking wire.

## 18. Secure hanger clamp

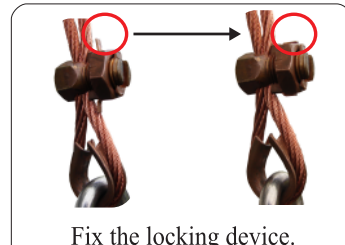

Fix the locking device.

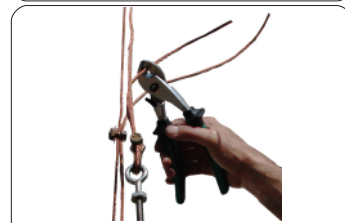

After complete hogging and fine adjustment cut the unnecessary hanger rope.

### Caution! Danger of accident if these points are not observed:

- The contact wire and messenger wire must lay vertically on each other at the installation location. Otherwise the hangers are not under continuous tension and optimal functioning is impossible. In extreme cases it may even occur that the current collector hooks into the runners at the spark gap which leads to damage.
- The screws at the contact wire clamps must be retightened three times. Otherwise the teeth do not grip the contact wire material completely. The contact wire could therefore slide out later and falling parts could cause damage of material or even injure people.
- The screws must be restrained with a ring wrench when tightening the counter nuts at the contact wire clamps. The screws could otherwise get loosened when tightening the counter nuts and this could cause the contact wire to slide out, damage material and injure people.
- The runners of the section insulator must be correctly adjusted as described. Otherwise shocks might damage the section insulator or the carbon sliders.
- Turnbuckles must be locked with counter nuts and secured with locking wires. These could otherwise open and the resulting incorrect position of the section insulator could cause malfunction of the overhead line.
- All screws and nuts must be tightened correctly according to the description. They could otherwise become loosened by vibration and cause malfunction of the overhead line.
- Should the protective plastic finish of Silicone or PTFE of one of our insulators be so severely damaged, either that the glass fiber inside is visible or that humidity and dirt can obviously penetrate, the insulator must be replaced immediately. Otherwise a high-voltage flash-over could damage the insulator and the overhead line.
- Arthur Flury AG rejects responsibility for any damage caused by not observing this installation instruction.

## 19. Check alignment

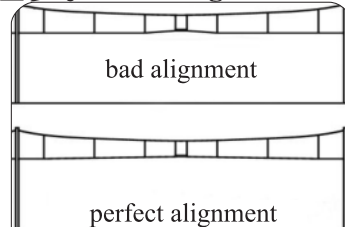

Adjust the next 3 hangers in both directions.

## Maintenance and Service

A well adjusted section insulator of Arthur Flury AG does not require any maintenance for a long period of time.

### Insulator

The cover of the insulating rod is cleaned well enough by rain water under normal circumstances. In case of exceptionally strong dirt accumulation (for instance from frequent diesel traffic, installation in a tunnel and so on) we suggest cleaning the insulator once a year with water slightly soaped water.

The Insulator must be replaced if the GRP rod becomes visible through damage of the cover.

### Runner

Well adjusted runners need to be checked first after approximately 200'000 to 300'000 passages of current collectors and to be readjusted in case of wear >3 mm [1/8"].

Should the wear have reached the maximum value (bulb only 1 – 2 mm [1/16"] thick) the runners must be replaced.

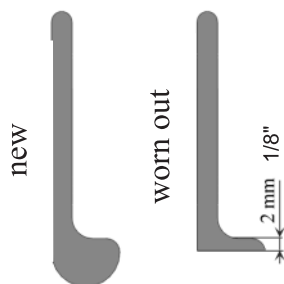

## Recommendations and Trouble shooting of AF Insulators

### a) Notice:

A well adjusted section insulator can be raised by a spring balance at any extreme point of the runners (tips of runners at the arcing horns) applying 120 N [26 lbf] without releasing the hanger load. If hangers get loose, the insulator must be hung higher step by step each 10 mm [3/8"] until it remains straight.

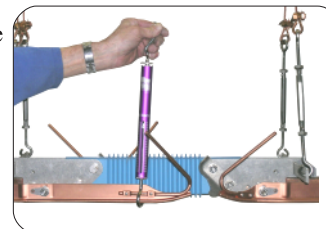

### b) Performance:

The AF section insulator must provide a constant performance for passing current collectors and remain stable. Observe the suspension while passing current collectors. If it swings strongly or gets loose, the pantograph presses the section insulator too much and tries to lift it. In this case the section insulator must be positioned higher so that the suspension remains stable when being passed.

### c) Excessive wear of runners:

It is a sign of inaccurate adjustment if the runners show excessive wear at the intake point. They must be readjusted according to the detailed installation instructions. Well adjusted runners show a constant wear from the beginning till the end of the section insulator.

